

Boxspring Lift

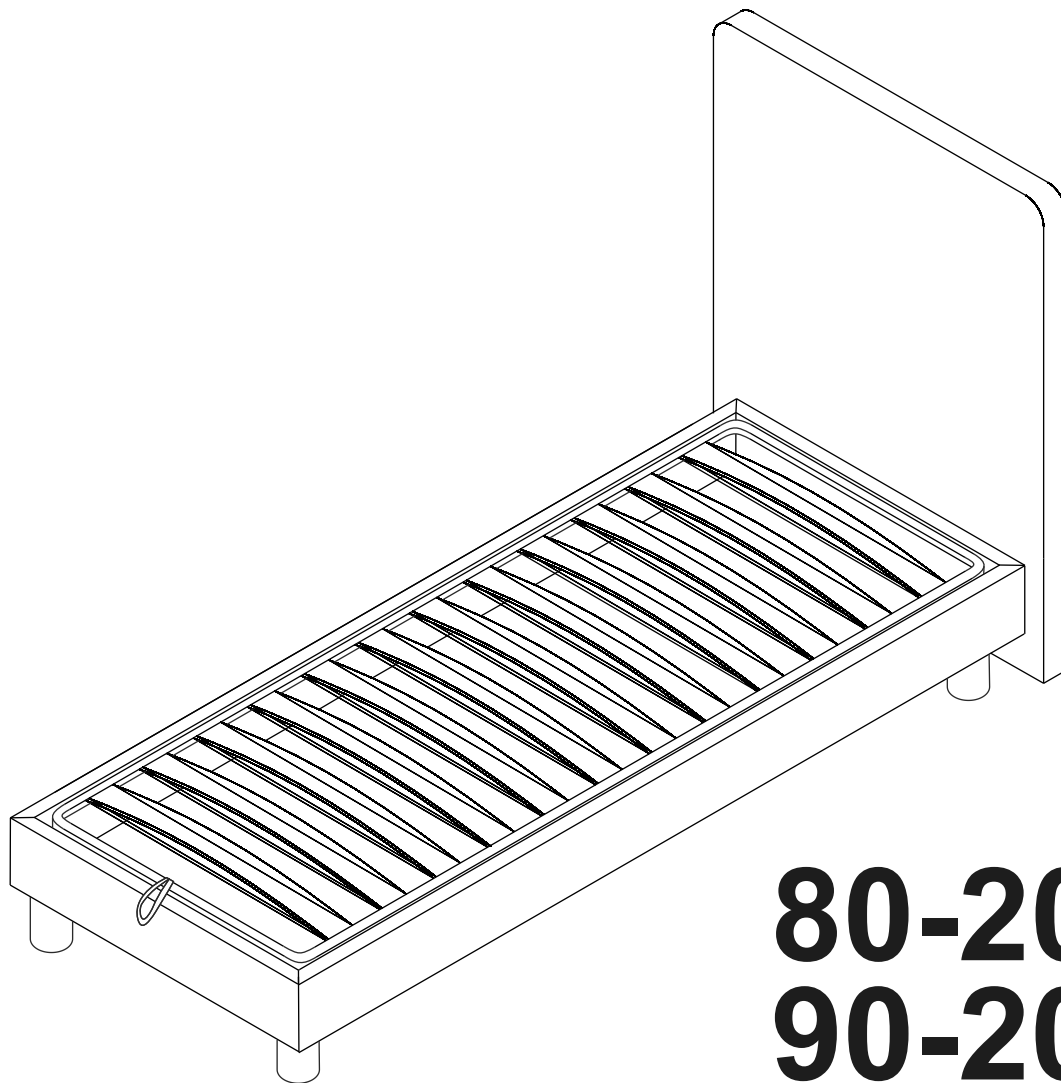

80-200

90-200

100-200

PROxSON

правила хорошего сна

1

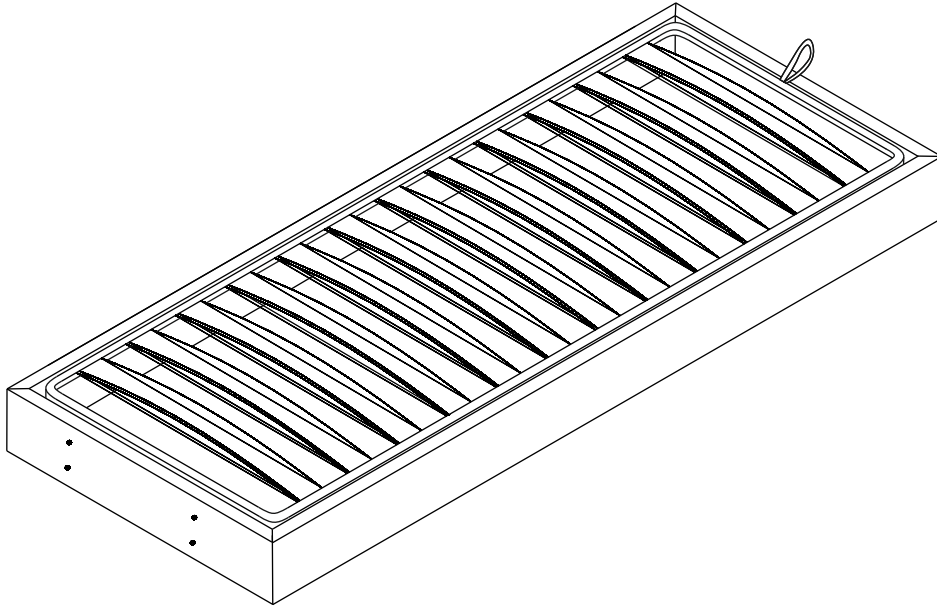

1x

2

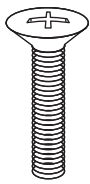

8x



2x

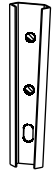

2x

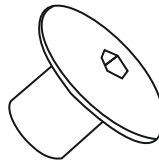

4x

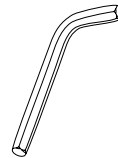

1x



4x

1

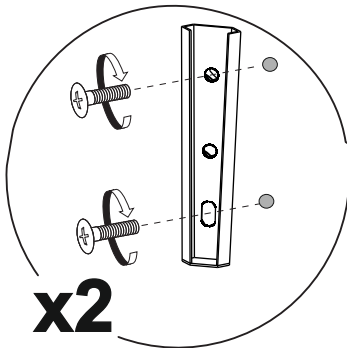
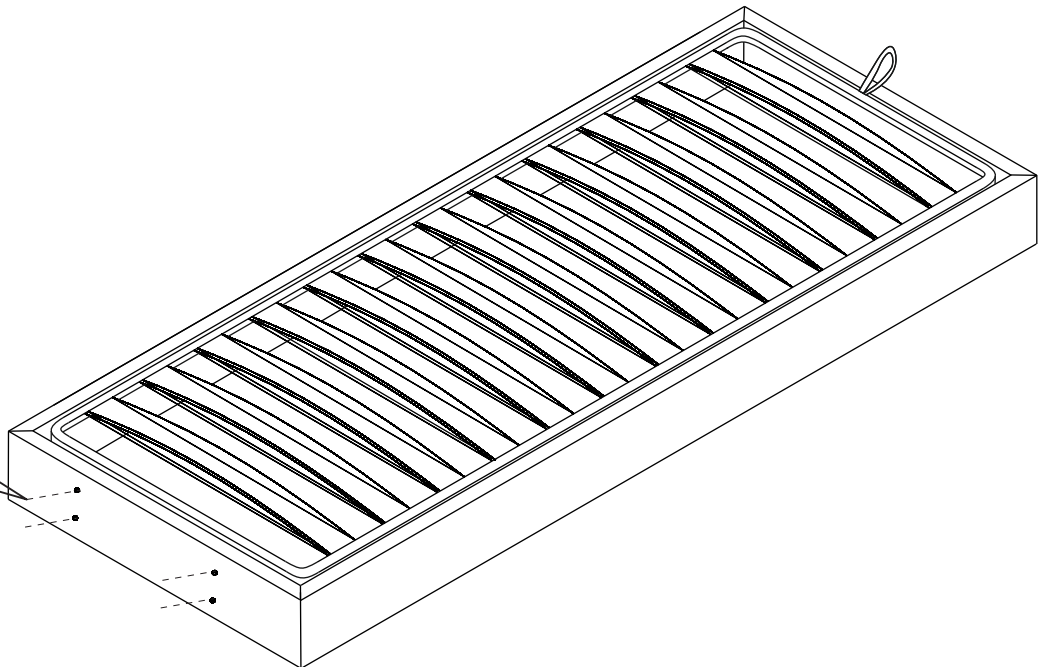

x2

2

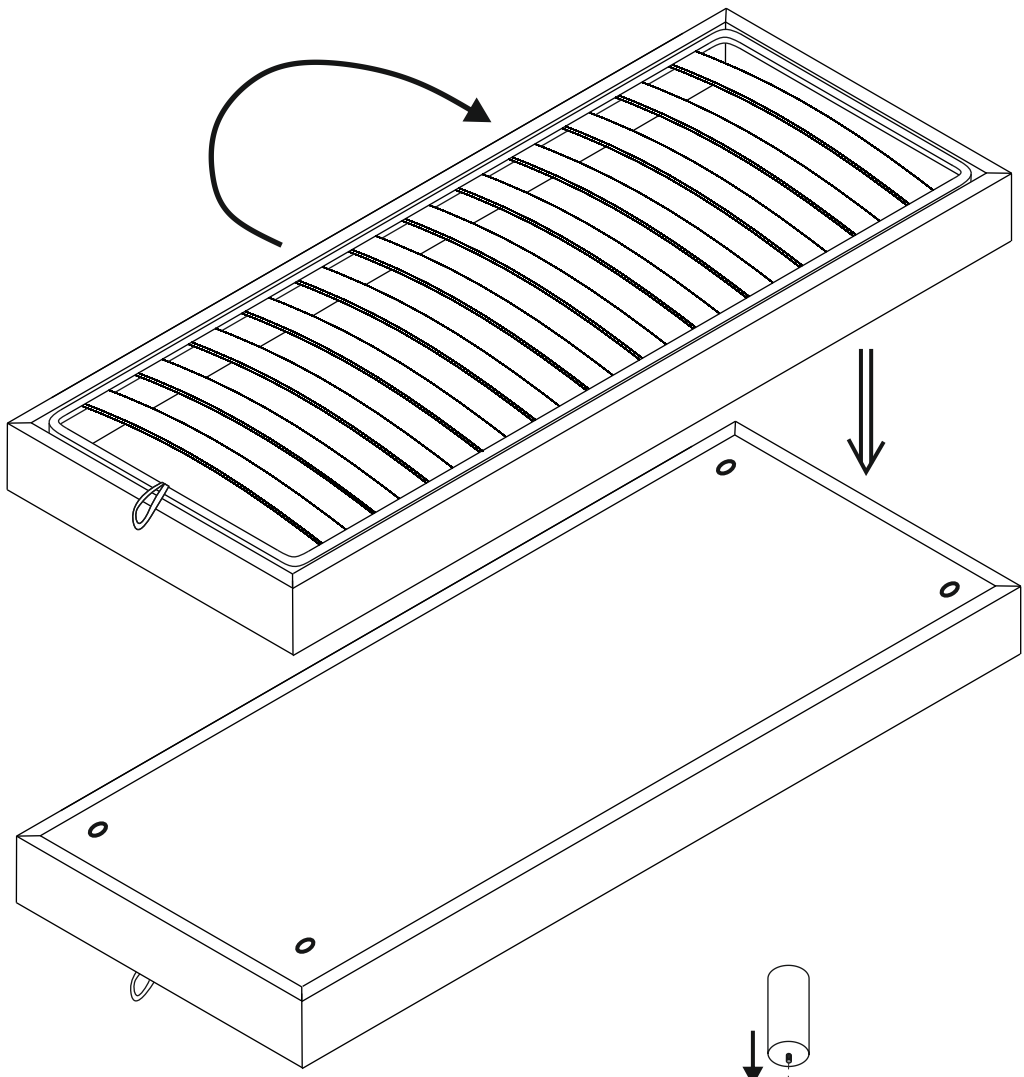

3

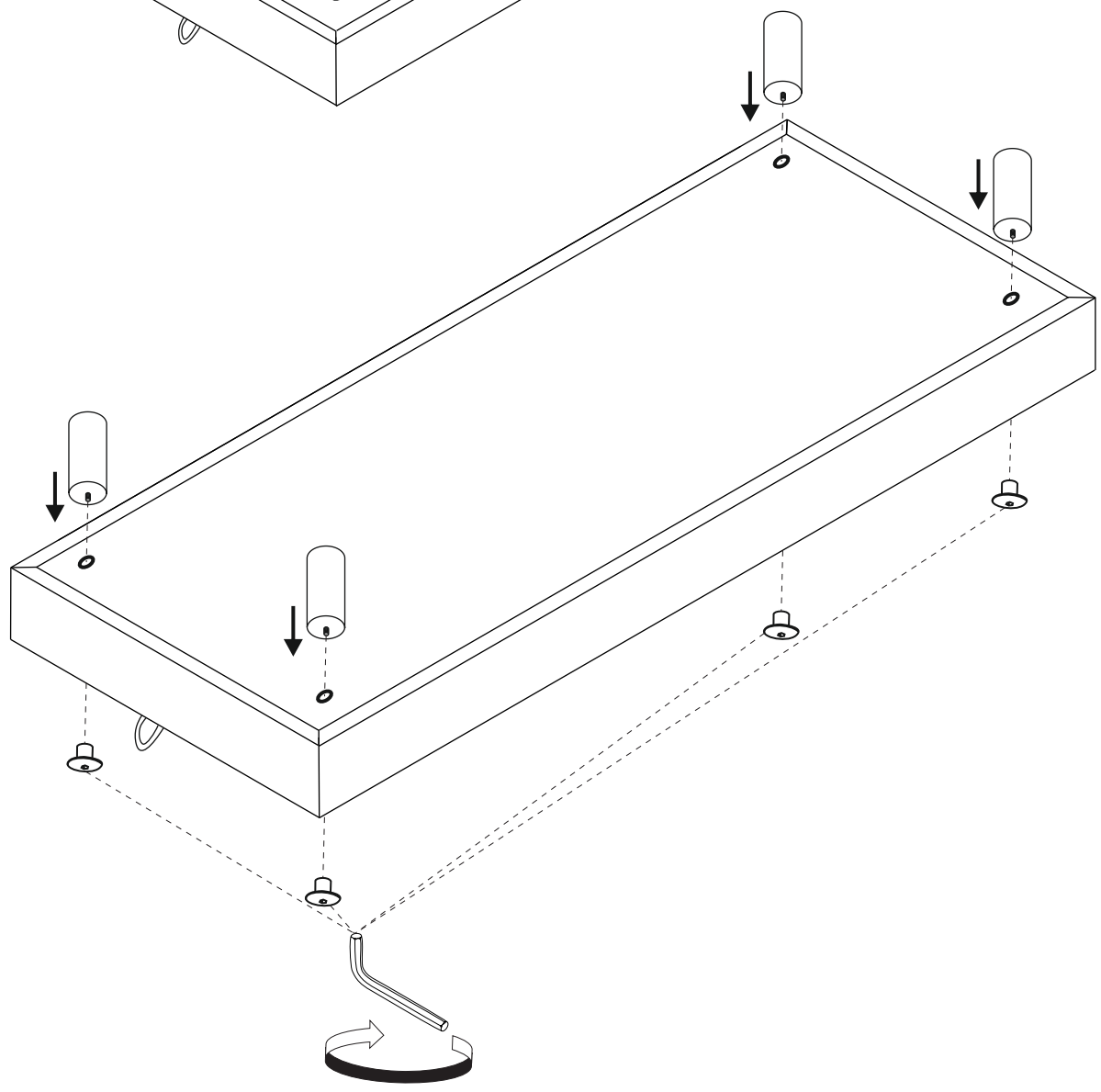

4

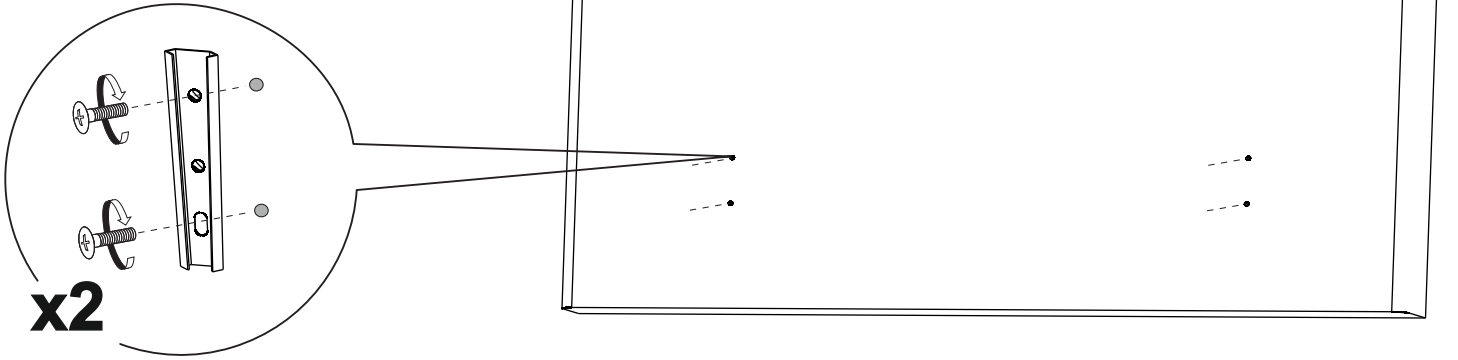

5

