

- |  |                             |
|--|-----------------------------|
| 1.  Шток - 4 шт.                                 | 1.1  Эксцентрик - 4 шт.     |
| 2.  Евровинт 6x50 - 54 шт.                       | 3.  Шкант 8x30 - 8 шт.      |
| 4.  Винт М6х30 - 23 шт.                          | 5.  Винт М6х40 - 6 шт.      |
| 6.  Ключ - 1 шт.                                 | 7.  Саморез 3x16 - 20 шт.   |
| 8.  Подпятник - 7 шт.                            | 9.  Опора колесная - 10 шт. |
| 9.  Заглушка пластиковая для эксцентрика - 2 шт. |                             |

**Инструкция по сборке кровати Martin**

1

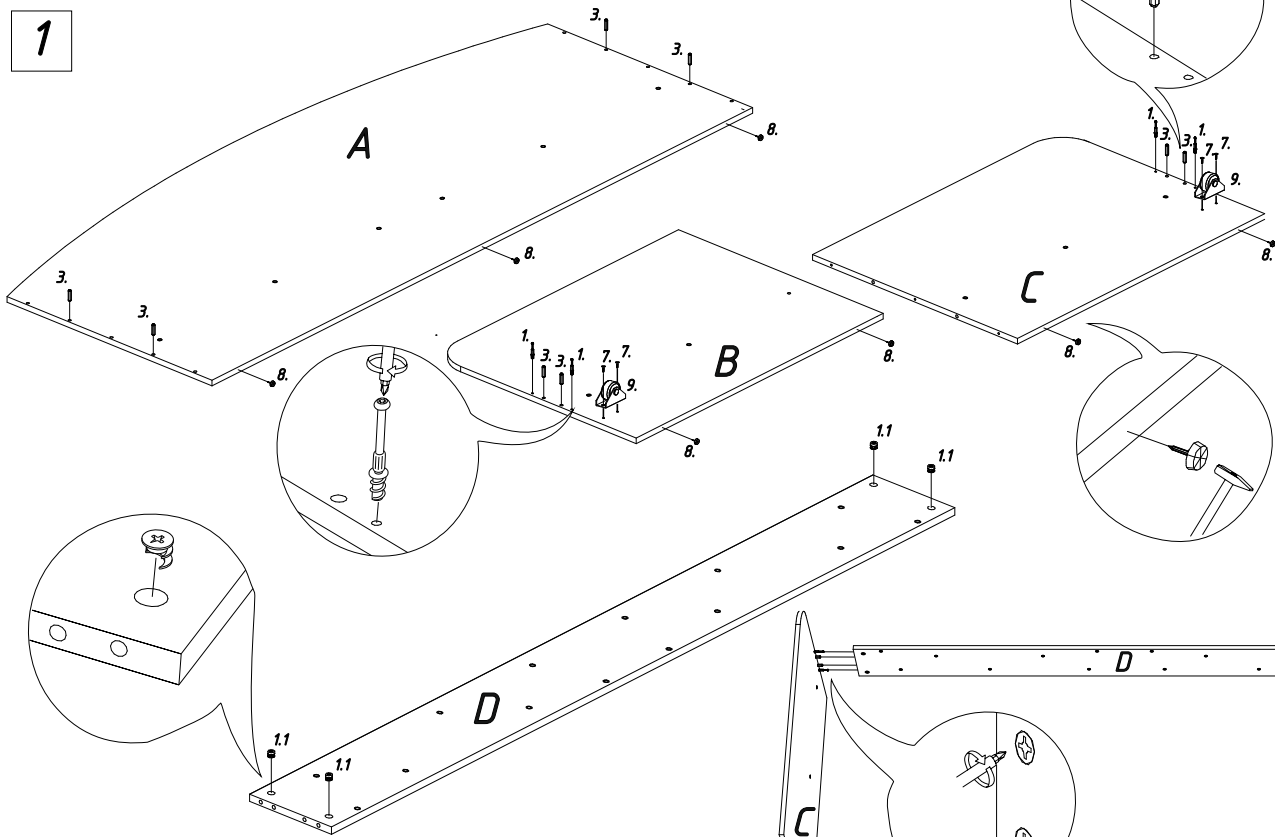

2

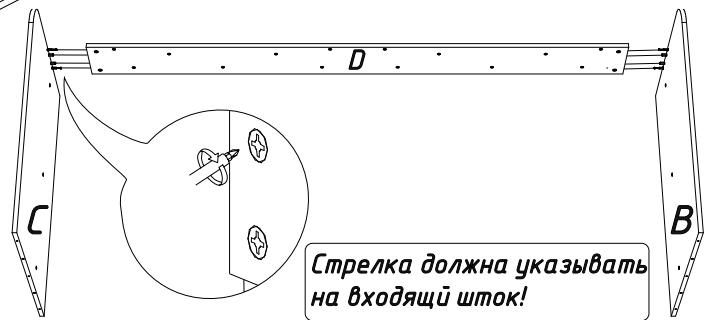

3

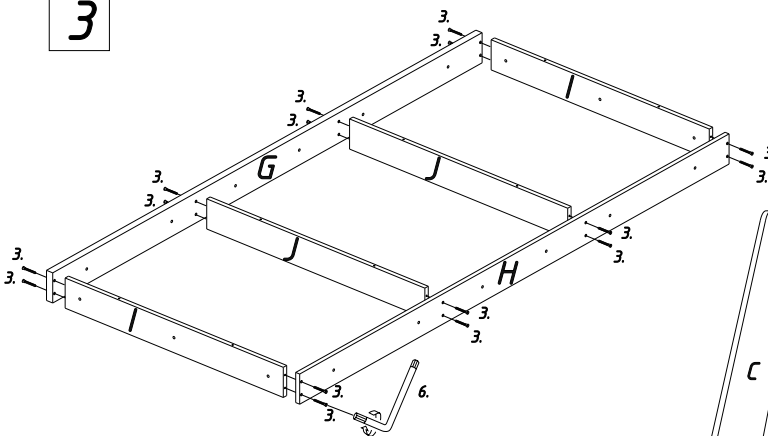

4

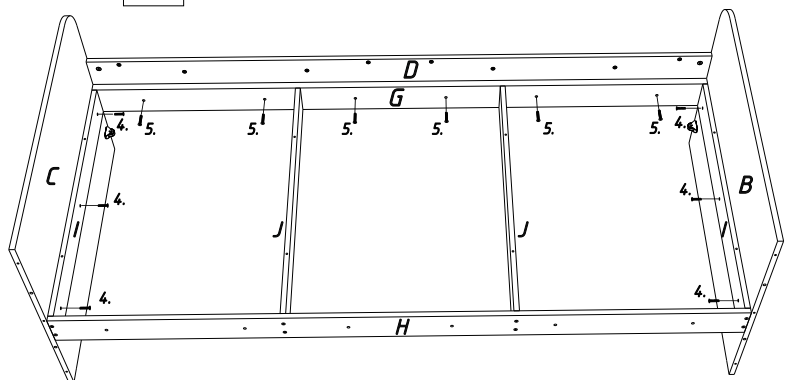

5

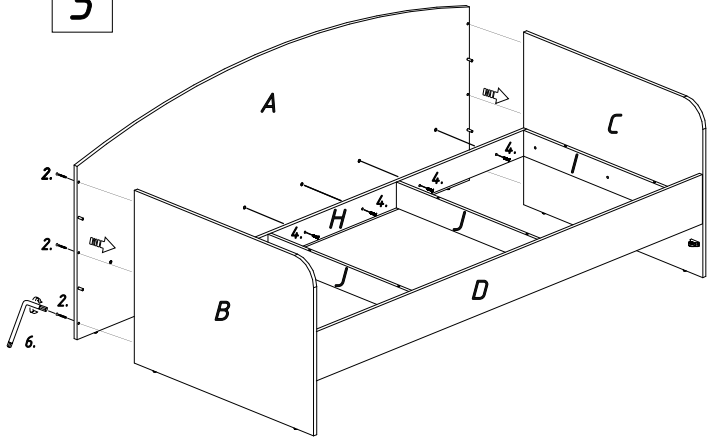

6

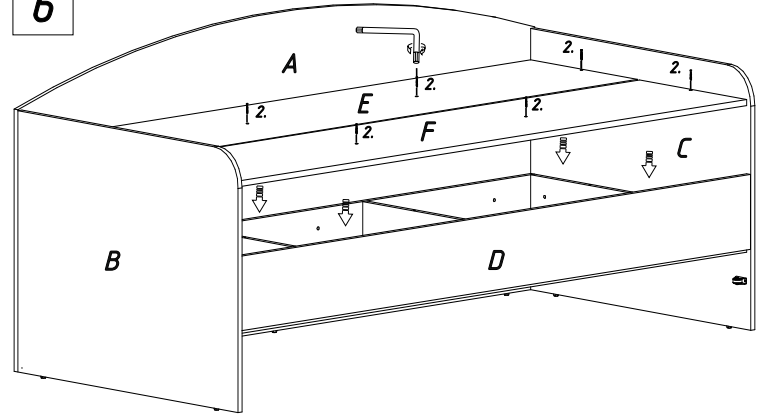

7

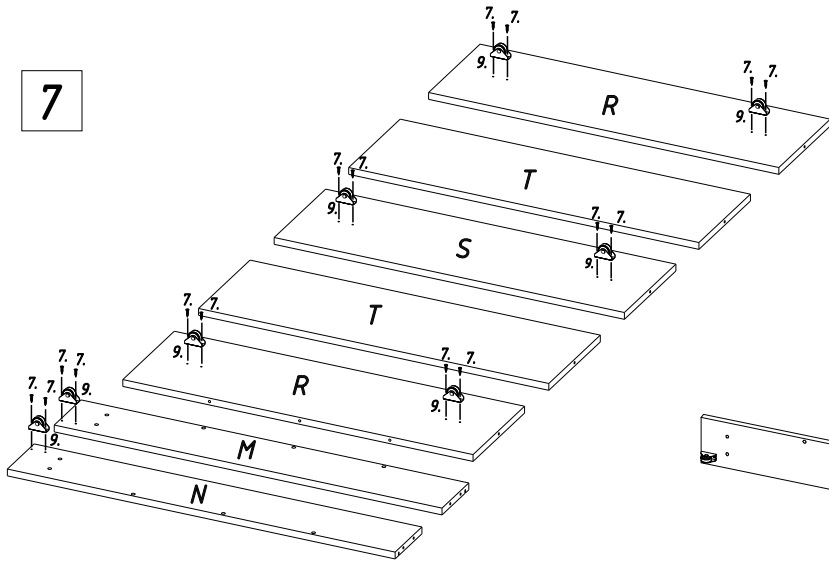

8

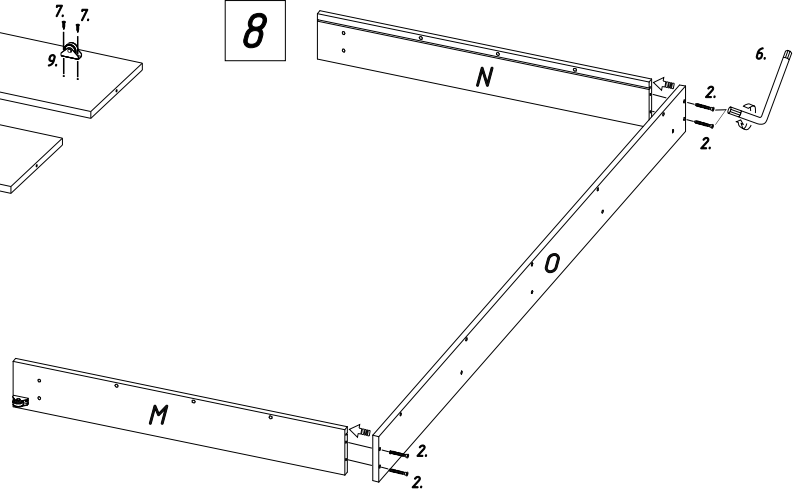

9

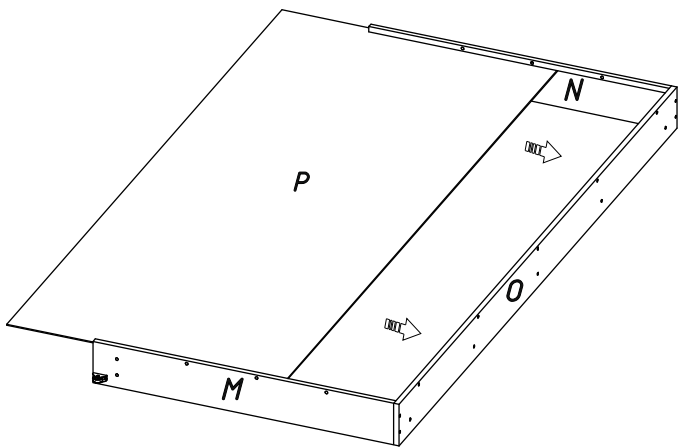

10

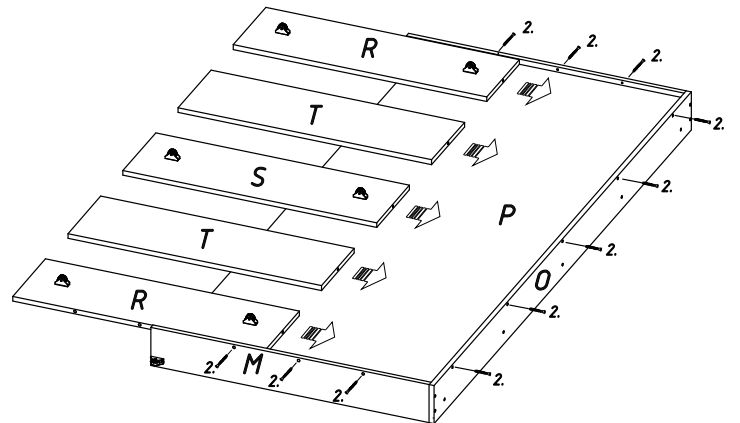

11

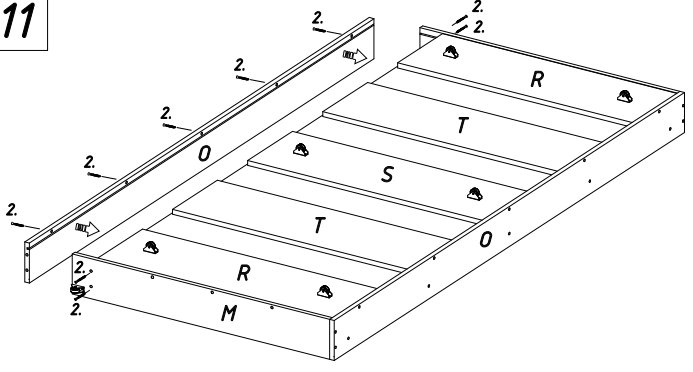

12

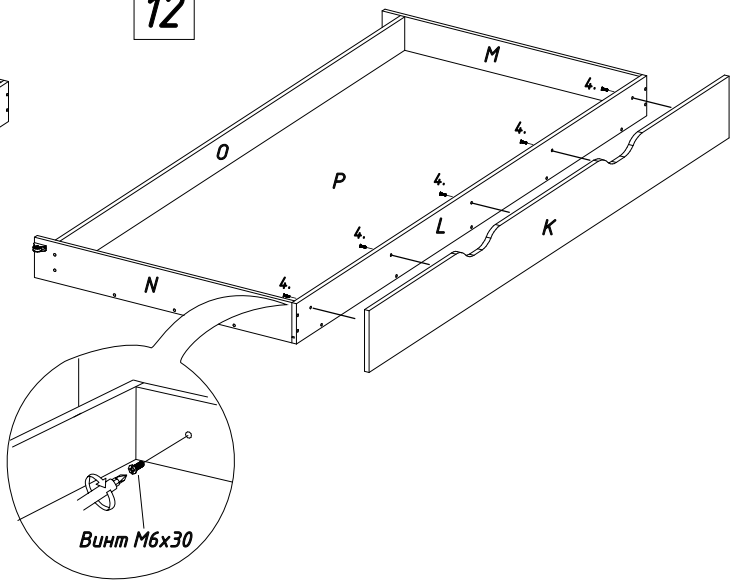

Винт М6х30

13

